



BOLLARDS



BICYCLE PARKING

NESPRESSO

Brochure Edition II 2018



Capability & Product Range

能力 & 產品範圍

OVERVIEW

概觀

 **SecuraPost**

 **SecuraBike**



25

Years in operation
經營多年50,000+
Projects completed
項目已完成

BOLLARDS



BICYCLE PARKING



SWING/BOOM GATES



LEDA offers an array of innovative products for commercial and government buildings.

为商业和政府建筑提供一系列创新产品

THE LEDA DIFFERENCE

- High manufacturing standards for durability and low maintenance
高耐久性和低维护的制造标准
- Cost efficient end-to-end process for customers
为客户提供经济高效的端到端流程
- Design innovation and contemporary styling
设计创新和现代风格
- High vandal resistance
高防破坏性
- Unparalleled installation expertise
无与伦比的安装专业知识
- Extensive technical resources and advice included
包括广泛的技术资源和建设
- Independently-tested, crash-rated barriers
经过独立测试，碰撞等级的障碍

ABOUT LEDA

LEDA commenced Australia operations in 1994 and has its main manufacturing plant located at Tuggerah NSW. In 2012, LEDA opened its own factory and offices in Ningbo China, to service sales in that country as well as catering for global markets.

LEDA於1994年開始在澳大利亞運營，其主要製造工廠位於新南威爾士州的

Tuggerah NSW. 2012年，LEDA在中國寧波開設了自己的工廠和辦事處，為該國的銷售提供服務，並為全球市場提供服務。

ACROSS AUSTRALIA & CHINA

LEDA sales are based in Sydney, Melbourne, Brisbane, Perth, Adelaide & Ningbo China

We have distributors in New Zealand, Europe, North & South America.

LEDA
CHINA

LEDA

PRODUCT RANGE 產品範圍

The current Leda range centre's on 2 core product areas:

1. Securapost®

- Security Bollards
- Architectural Bollards
- Industrial Bollards
- Retractable Bollards
- Lighting Bollards



2. Securabike®

- Bicycle racks
- Bicycle lockers
- Bicycle rails
- Bicycle cages
- Bicycle shelters
- Bicycle repair station



Comprehensive brochures and technical literature on the complete range of LEDA's architectural and security products are available on request or visit the websites:

有關LEDA的全系列建築和安全產品的綜合手冊和技術文獻可根據要求提供或訪問網站：

ledasecurity.com.cn

securabike.com.cn





SHARING OUR POTENTIAL 分享我們的潛力



CUSTOMERS 顧客

Our major market segments include: 我們的主要細分市場包括:

- Architectural 建築的
- Building & Construction 建築與施工
- Government Dept's and Utilities 政府部門 和公用事業
- Universities 高校
- Commercial and Industrial markets 商業和 工業市場
- Security Resellers 安全經銷商
- Clubs & Recreation 俱樂部和娛樂
- Property Managers 物業經理
- Shopping Centers 購物中心
- Hospitals 醫院



LEDA
CUSTOMER EXPERIENCE IS
END-TO-END

客戶體驗是
結束-至-結束



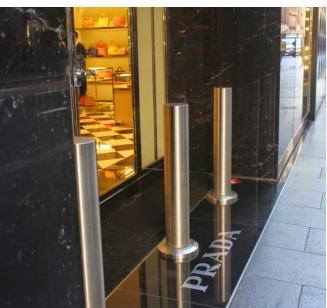

The comprehensive range of models includes traditional and stylish contemporary designs manufactured in a range of materials and styles and falls into four categories:

全系列的模型包括以各种材料和款式制造的传统和时尚的现代设计, 分为四类:

- Architectural 建筑的
- Security 安全
- Retractable 伸缩
- Industrial 产业

Materials

- Stainless Steel 不锈钢
- Aluminium 铝
- Timber 木材
- Steel 钢

Available in

- Locking & Removable 锁定和可拆卸
- Fixed Insitu 固定
- Baseplate 底盘
- Retractable 伸缩

SecuraPost

Architectural Range

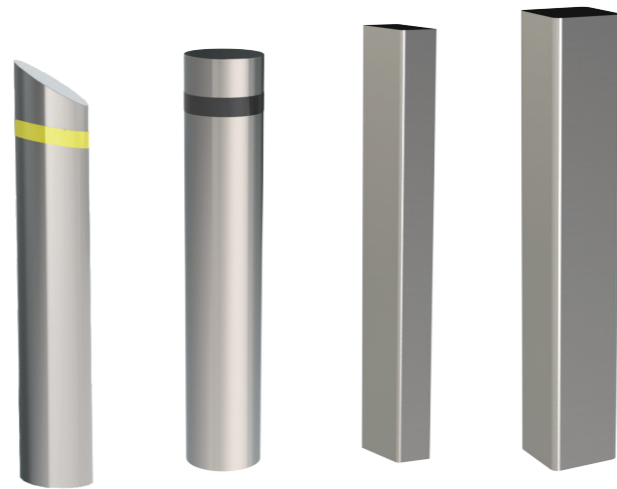

Stainless Steel Range

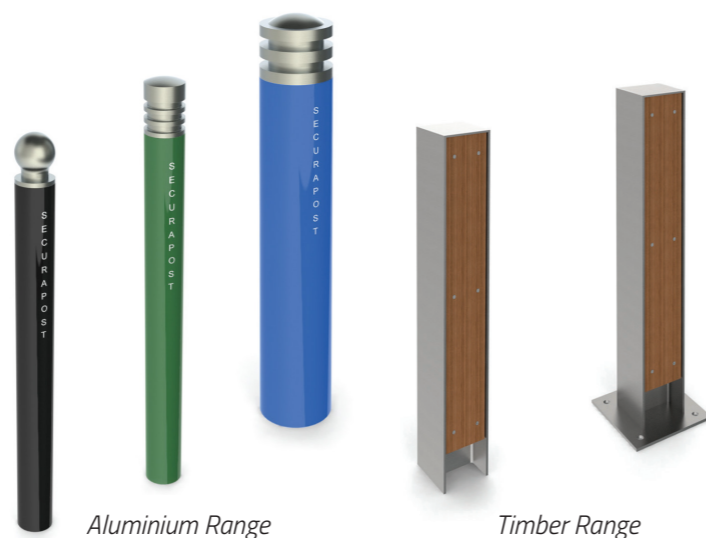

Aluminium Range

Timber Range

Security Range



Sentinel Series

Super XP

IBR Series



SecuraPost

Retractable & Industrial Range



Industrial Range



Power Distribution Bollards

Card Reader Bollards

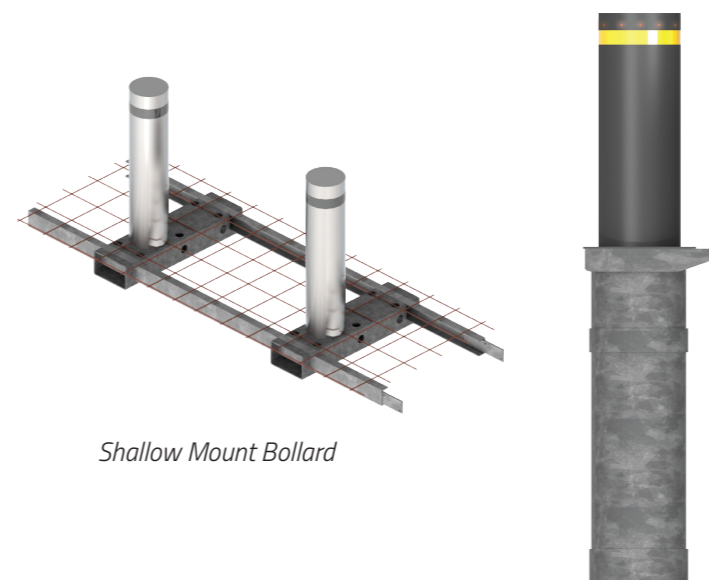

Shallow Mount Bollard

Retractable Bollard



Applications

- Building perimeters
- Shopping centres & malls
- Government sites
- Industrial complexes
- Public and community areas
- Schools and universities
- Alfresco dining areas



應用

- 建築周邊
- 購物中心和購物中心
- 政府網站
- 工業園區
- 公共和社區領域
- 學校和大學
- 露天用餐區





LEDA China's extensive range of bicycle security products and end-of-journey facilities are designed to cater for virtually every type of application.

LEDA 中國廣泛的自行車安全產品和終端設施旨在滿足幾乎所有類型的應用

Materials

- Hitching Rails 搭便車
- Racks 架
- Shelters 避難所
- Cages 籠
- Lockers 儲物櫃
- End-of-Journey Facilities 旅行結束設施
- Skateboard & Scooter Racks 滑板和滑板車架
- Repair Station & Tools 維修站和工具

SecuraBike



Bike Rails



Horizontal Bike Racks

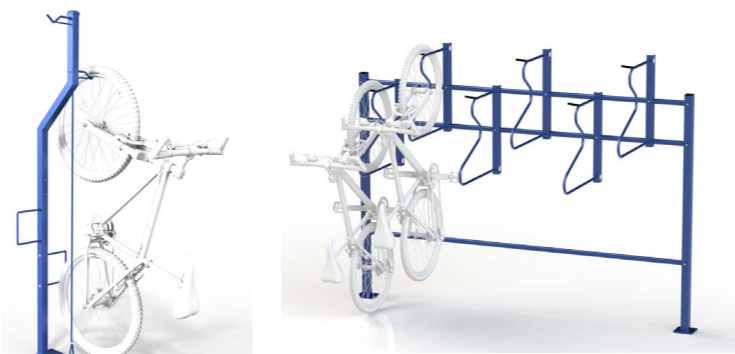

Vertical Bike Racks



Wall Mount Racks



Double Storage Racks



Bike Repair Stations



Scooter Racks



SecuraBike



Bike Lockers



Bike Cages



Bike Shelters



Bike Enclosures



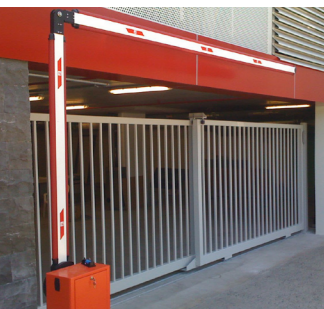

LEDA China gates are manufactured from strong RHS steel sections and supplied with heavy duty drive motors and gear boxes. Infill and 'top' options are available for most gates.

LEDA 中國大門由堅固的RHS 鋼製成 並配有重型驅動電機和齒輪箱. 大多數門都可以使用填充和“頂部”選項.

Product Range

- Industrial Boom Gate
工業繫帶門
- Portable Solar Boom Gate
便攜式太陽能門
- Defender Security Gate
後衛安全門
- Industrial Swing Gate
工業擺動門
- Manual Swing Gate
手動擺動門
- Industrial Sliding Boom
工業滑動臂
- Full Height Turnstiles
全高旋轉門
- Pedestrian Gates
行人門

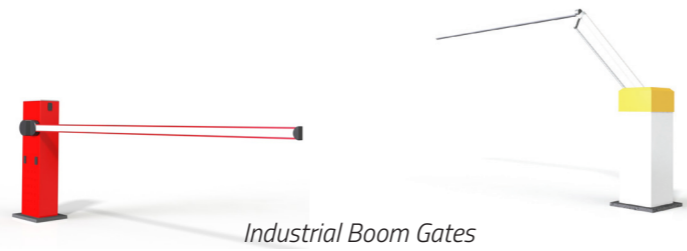

Industrial Boom Gates

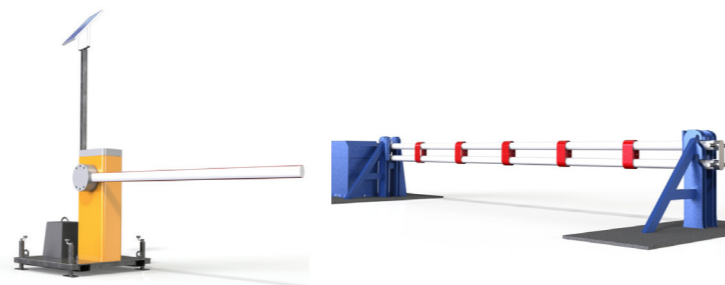

Portable Solar Boom

Defender Security Gate



Industrial Swing Gate



Manual Swing Gate



Industrial Sliding Boom



Full Height Turnstiles

Pedestrian Gates



LEDA HAS A RANGE OF CRASH RATED & NON-CRASH RATED PRODUCTS
LEDA 具有一系列的碰撞等級和



Need product advice, information or further technical resources?

需要產品建議, 信息或進一步的技術資源?

Call LEDA China now on 現在打電話

+86 574 8856 8111



ledasecurity.com.au

ledasecurity.com.cn

**Head Office &
Manufacturing**
總公司 & 製造業

**Offshore
Manufacturing**
海上製造業

NSW - Tuggerah
18 Reliance Drive
Tuggerah NSW 2259
PO Box 5196
Chittaway Bay 2261
Tel: (02) 8413 3430

Ningbo - China
26 JuYing Road
MinCheng Industrial Park
Jiangkou Fenghua
Ningbo, P.R. China 315504
Tel: (+86) 574 8856 8111

follow us in

跟著我們



INTERNATIONAL SALES BRANCHES 国际销售分支机构

Email: sales@ledasecurity.com.au

New South Wales

8/185 Briens Road,
Northmead, NSW 2152
Tel: (02) 8413 3410

Queensland

2/387 Lytton Road
Morningside, QLD 4170
Tel: (07) 3613 8270

Victoria

2/89 Enterprise Way
Sunshine West VIC 3020
Tel: (03) 8399 8150

South Australia

1/5 Tooronga Ave
Edwardstown, SA 5039
Tel: (08) 8374 3266

Western Australia

1/27 Century Road
Malaga WA 6090
Tel: (08) 6430 1670

Australasian distributors and resellers in Northern Territory, Tasmania and New Zealand.

Distributed by